

Product Advantages

The M series sleeve control valve is a cage-guided double-seat control valve. The valve core is designed based on the principle of fluid dynamic balance, allowing high-pressure differential conditions to be controlled with a smaller actuator thrust. The sleeve adopts a quick-change structure, enabling rapid online replacement of internal valve components. The valve body features a high-strength spherical structure, and the entire series is designed with a modular concept, allowing different components to be freely combined and interchanged.

Applicable Industries

1.2

Depending on the working conditions, it can be equipped with pneumatic or electric actuators. The entire machine operates smoothly, responds quickly, has a wide adjustable range, and is easy to maintain. It can be used to control various fluids under different working conditions and is suitable for various harsh working environments. It is widely used in the petroleum, chemical, power, light textile, pharmaceutical, and paper-making industries. It is particularly suitable for applications with a large pressure difference before and after the valve, where leakage requirements are not very high.

Valve Body

Type	Control Valve	Flow Characteristics	Equal percentage or Linear	Nominal Diameter	DN20~DN400 (3/4~16")
Body Type	Cage Guide	Leakage	IV, V, VI	Connection Method	Flange, Thread, Welding
Nominal Pressure	PN16~PN160, Class 150~Class 900			Applicable Temperature	-196~+60°C, -29~+250°C, -29~+560°C
Bonnet Type	Standard, Control and Cut-off, High-temperature, Low-temperature, Bellows Sealing				

Main Materials

Valve Body, Valve Bonnet

WCB, WC6, WC9, LCB,
CF8, CF8M, CF3, CF3M

Valve Plug, Valve Seat

304, 316, 304L, 316L
Above + PTFE
Above + Hard Alloy Hardening Treatment

Bellows

304, 316, 304L, 316L, 316Ti, HC

Packing

PTFE, Graphite

Gasket

Stainless Steel+Graphite

Diaphragm

Nylon Reinforced NBR, EPDM, Viton

Spring

60Si2Mn

Stem

2Cr13, 3Cr13, 17-4PH, 660, XM-19
304, 316, 304L, 316L

Note: Other materials can be provided upon special request. The specific material models will be subject to the purchase order contract.

M Series Cage Guided Control Valve

Product Structure

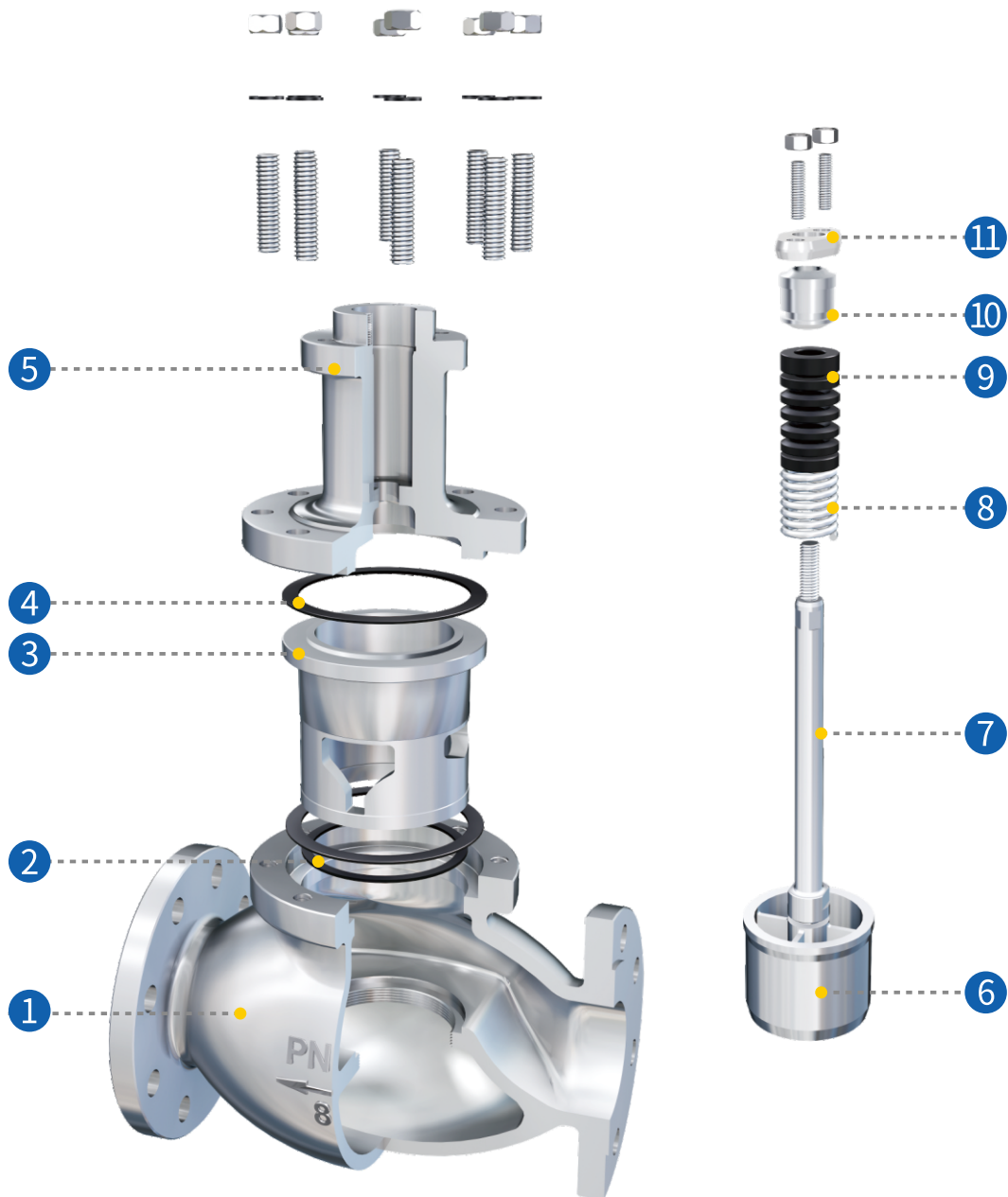

1.2

1	Valve Body	4	Gasket	7	Stem	10	Packing Press
2	Gasket	5	Bonnet	8	Spring	11	Packing Gland
3	Cage	6	Plug	9	Packing		

Bonnet Type

Standard Bonnet

Operating Temperature: $-29\sim+250^{\circ}\text{C}$, Leakage Class IV and V (Figure 1)

High-Temperature Bonnet

Valve Cover with Additional Fins: Suitable for medium temperatures of $-60\sim+560^{\circ}\text{C}$ (Figure 3)

1.2

Low-Temperature Bonnet

Complete Seal for Moving Valve Stem: Prevents fluid leakage (Figure 4)

Bellow Sealing

Long Neck Valve Cover with Bellows Seal Structure: Suitable for cryogenic conditions of -196°C (Figure 5)

Cut-off Valve Cage

Soft Seal Structure: Valve leakage class can reach Class VI (micro-bubble level) (Figure 6)

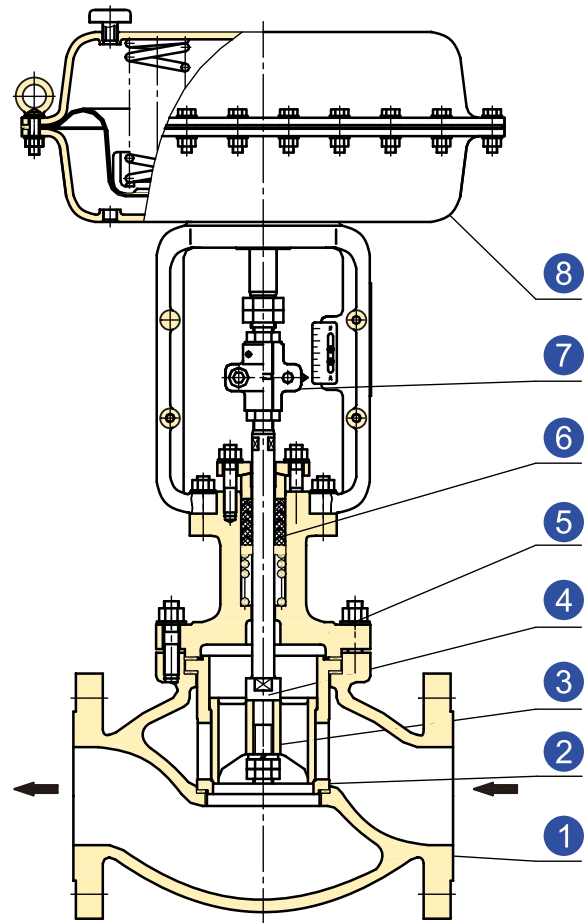

- ① Body ② Cage ③ Plug ④ Stem
- ⑤ Bonnet ⑥ Packing ⑦ Clamping Block
- ⑧ Pneumatic Actuator

Fig. 1 Standard Bonnet (Pneumatic)

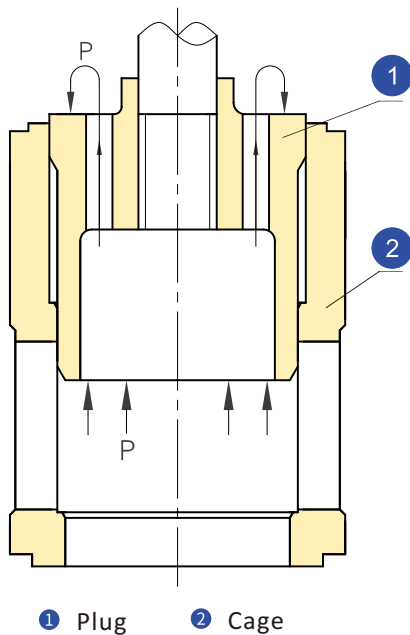

- ① Plug ② Cage

Fig. 2 Balanced Valve Plug

Pneumatic Actuated

Air to Close (FO)

When there is a gas supply failure, the actuator spring will open the valve.

Air to Open (FC)

When there is a gas supply failure, the actuator spring will close the valve.

Electric Actuated

Close When Energized (FO)

Open When Energized (FC)

M Series Cage Guided Control Valve

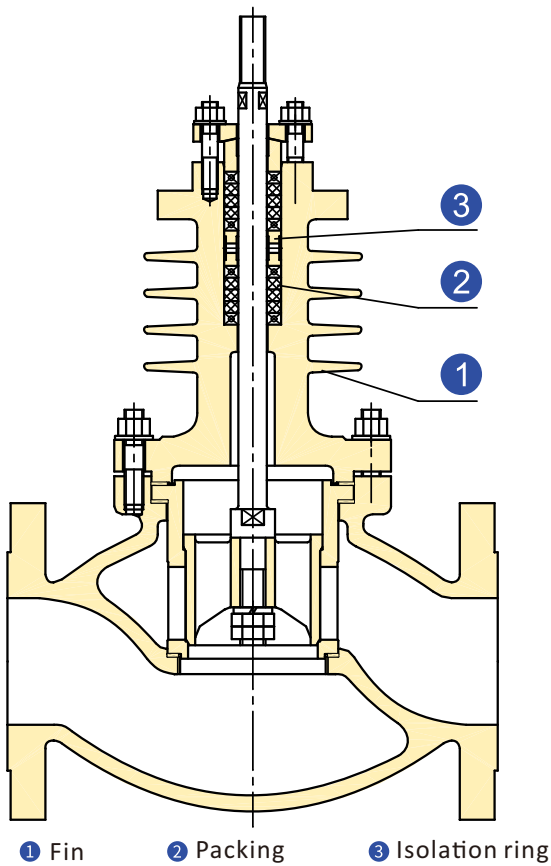

① Fin ② Packing ③ Isolation ring

Fig. 3 High-Temperature Bonnet

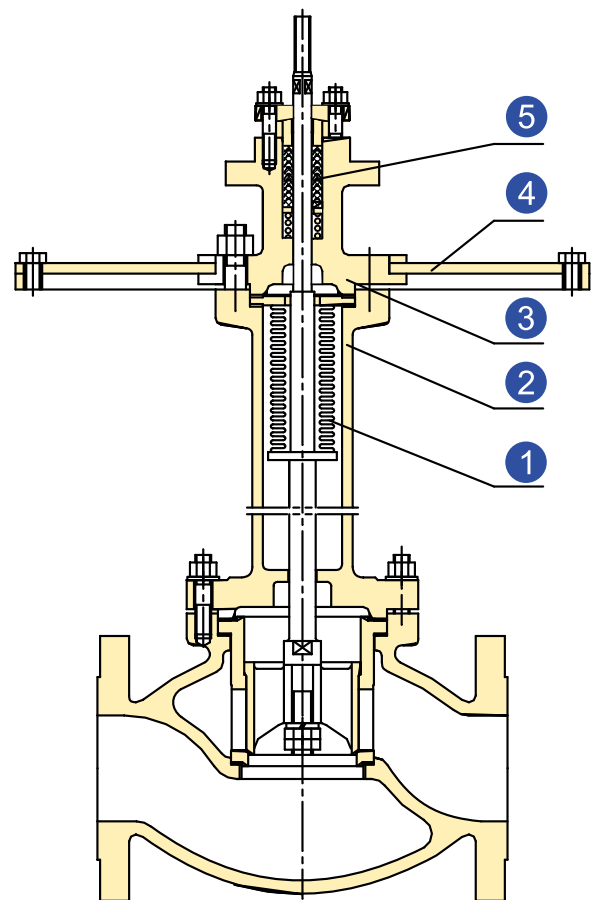

① Bellow ② Long-neck Bonnet ③ Bonnet
④ Cold box mounting flange ⑤ Packing

Fig. 5 Low-Temperature Bonnet

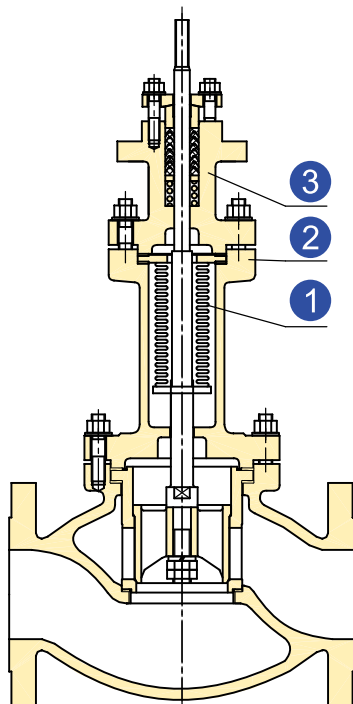

① Bellow ② Long-neck Bonnet ③ Bonnet

Fig. 4 Bellow Sealing

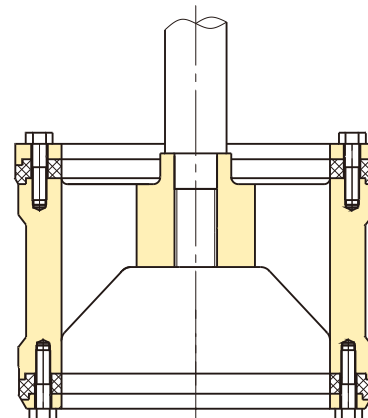

Fig. 6 Cut-off Valve Cage

Specifications

Table. 1

Nominal Diameter/ mm		20	25	32	40	50	65	80	100	125	150	200	250	300	350	400
Flow Capacity Kv	Linear	6.9	11	17.6	27.5	44	69	110	176	275	440	690	1100	1760	2750	3960
	Equal %	6.3	10	16	25	40	63	100	160	250	400	630	1000	1600	2500	3600
Rated Stroke/ mm		16		25		40		60		100		120	140			
Nominal Pressure		PN16~PN160, Class 150~Class 900														
Flow Characteristic		Linear, Equal Percentage														
Adjustable Ratio R		50														
Pneumatic Actuator	Direct	PM280B		PM400B		PM600B		PM1000B		PM1600B		PS400/500B				
	Reserve	PM280K		PM400K		PM600K		PM1000K		PM1600K		PS400/500K				
Effective Area/ cm²		280		400		600		1000		1600		—				
Spring Range/ KPa		20~100、40~200、80~240、160~320														
Supply Pressure/ MPa		0.14、0.25、0.28、0.40、0.50														
Electric Actuator	Model	360 Series, PSL Series, etc.														
	Power	220V.AC、380V.AC、24V														
Input Signal		4~20mA DC, 0~10mA DC and other control signals or the above signals for split-range control														

Note: The data in the table represents our company's standard configuration and can be customized according to user requirements.

Main Preference

Table. 2

No.	Description	Pneumatic Control Valve		Electric Control Valve	
		Standard	High & Low-Temperature	Standard	High & Low-Temperature
1	Basic Error < (%)	±1.0	±2.5	±1.0	±2.0
2	Hysteresis < (%)	1.0	2.5	±1.0	2.0
3	Dead Band < (%)	0.4	1.0	1.0	2.0
4	Rated Travel Deviation < (%)	±1.0	±2.5	±1.0	±2.0
5	Starting and Ending Point Deviation < (%)	+2.5	+2.5	2.5	+2.5

M Series Cage Guided Control Valve

Applicable Temperature and Pressure of Trim and Packing

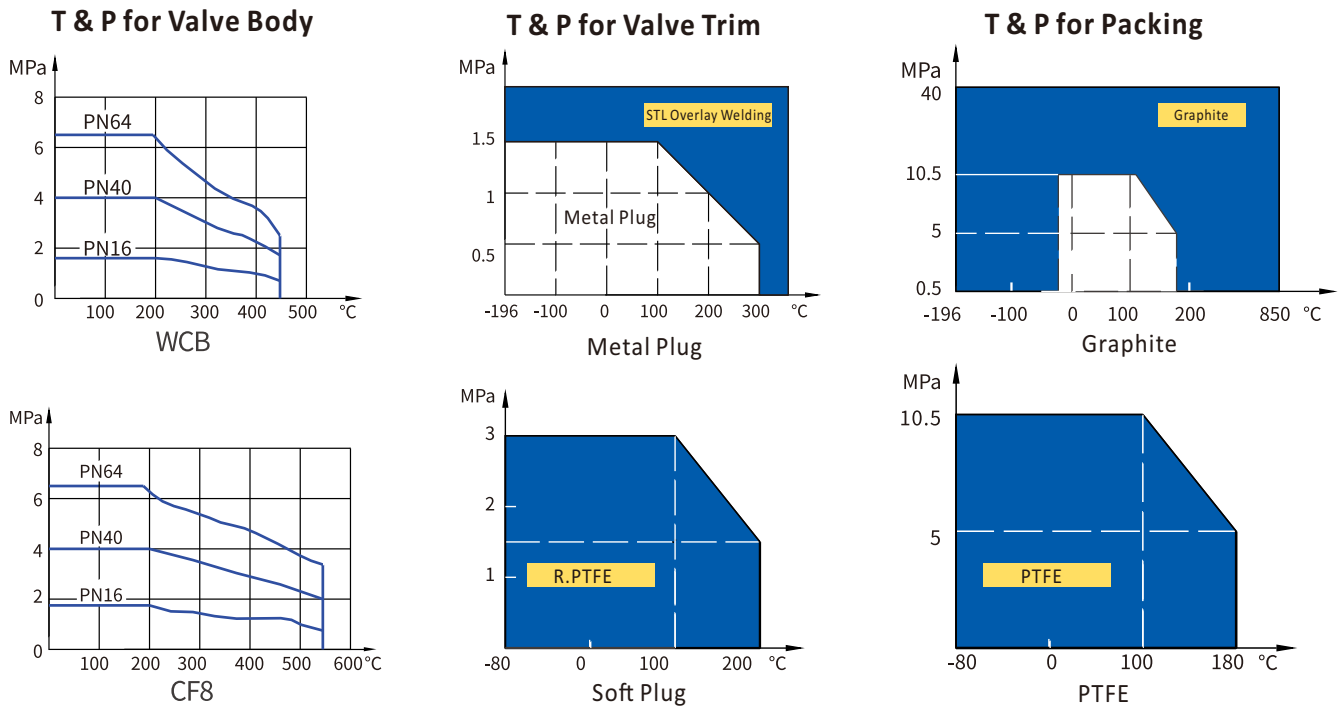

1.2

Various Materials, Temperature Range and Leakage

Table. 3

Nominal Diameter/ mm		20~400(3/4"~16")	
Body Material		WCB, LCB, WC6, WC9	CF8, CF8M, CF3, CF3M
Temperature Range			
Bonnet	Standard Bonnet	-29 ~ +250 °C	-40 ~ +250 °C
	High-Temperature Bonnet	-29 ~ +425 °C	-60 ~ +560 °C
	Bellow Sealing	-29 ~ +425 °C	-100 ~ +560 °C
	Low-Temperature Bonnet	-46 ~ +160 °C	-196 ~ - 60 °C
Plug	Metal Sealing	-196 ~ +450 °C	
	Soft Sealing	-29 ~ +200 °C	
	STL Overlay Welding	-196 ~ +560 °C	
Packing	PTFE	-40 ~ +160 °C	
	PTFE+Graphite	-60 ~ -20 °C、 +140~+200 °C	
	Graphite	-196 ~ +560 °C	
Gasket	F4	-60 ~ +200 °C	
	PTFE+Graphite	-196 ~ +560 °C	
Leakage			
Plug	Metal Sealing	IV, V	
	Soft Sealing	V, VI	
	STL Overlay Welding	IV, V	

Note: 1, For the number of bubbles, see ASME B16.104. 2, The data in the table represents our company's standard configuration and can be customized according to user requirements.

Flow Characteristic Curve

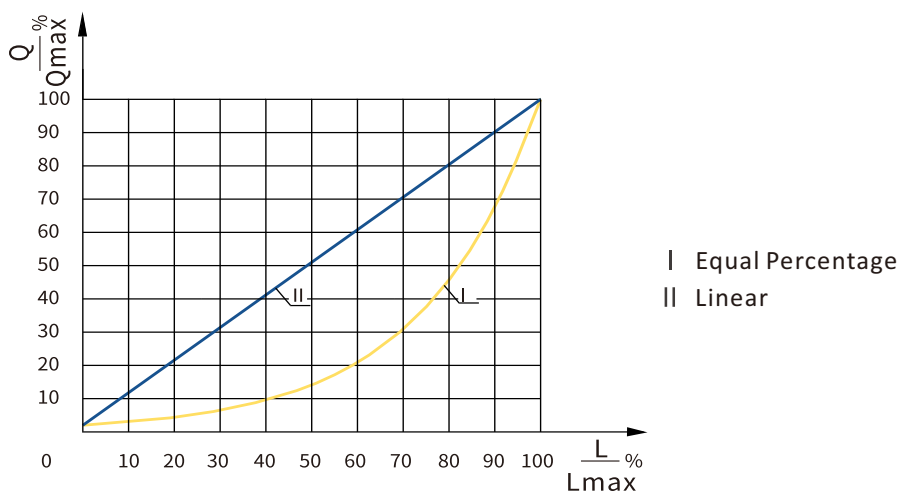

1.2

Table. 4 Relative Flow Values for Various Inherent Flow Characteristics at Relative Travel (R50) Unit: %

Flow Chara.	L/L max	0	10	20	30	40	50	60	70	80	90	100
Linear	Q/Q max	2	11.8	21.6	31.4	41.2	51	60.8	70.6	80.4	90.2	100
Equal Percentage	Q/Q max	2	3	4.37	6.5	9.6	14.1	20.9	30.9	45.7	67.6	100

Maximum Differential Pressure

Table. 5 Air-to-Close Metal Sealing Type Unit: MPa

Actuator Model	Spring Range Kpa	Air Supply MPa	Positioner	Nominal Diameter/ mm											
				20	25	32	40	50	65	80	100	125	150	200	
PM280B	20~100	0.14	—	0.80	0.66										
			✓	3.98	3.32										
	40~200	0.25	✓	5.57	4.64										
			80~240	0.4	✓	10.0	10.0								
PM400B	20~100	0.14	—			0.75	0.62	0.51							
			✓			3.76	3.09	2.53							
	40~200	0.25	✓			5.27	4.33	3.54							
			80~240	0.4	✓			10.0	10.0	9.62					
PM600B	20~100	0.14	—						0.63	0.51	0.42				
			✓					3.13	2.57	2.08					
	40~200	0.25	✓					4.38	3.60	2.92					
			80~240	0.4	✓				10.0	9.78	7.92				
PM1000B	20~100	0.14	—									0.54	0.45	0.34	
			✓									2.69	2.26	1.71	
	40~200	0.25	✓									3.77	3.16	2.39	
			80~240	0.4	✓								10.0	8.58	6.49

M Series Cage Guided Control Valve

Table. 6 Air-to-Open Metal Sealing Type

Unit: MPa

Actuator Model	Spring Range Kpa	Air Supply MPa	Positioner	Nominal Diameter/ mm											
				20	25	32	40	50	65	80	100	125	150	200	
PM280K	20~100	0.14	√, -	0.80	0.66										
	40~200	0.25	√	3.98	3.32										
	80~240	0.28	√	10.0	8.62										
PM400K	20~100	0.14	√, -			0.75	0.62	0.51							
	40~200	0.25	√			3.76	3.09	2.53							
	80~240	0.28	√			9.79	8.05	6.58							
PM600K	20~100	0.14	√, -						0.63	0.51	0.42				
	40~200	0.25	√						3.13	2.57	2.08				
	80~240	0.28	√						8.13	6.69	5.42				
PM1000K	20~100	0.14	√, -									0.54	0.45	0.34	
	40~200	0.25	√									2.69	2.26	1.71	
	80~240	0.28	√									7.00	5.87	4.44	

1.2

Table. 7 Air-to-Close Soft Sealing Type

Unit: MPa

Actuator Model	Spring Range Kpa	Air Supply MPa	Positioner	Nominal Diameter/ mm											
				20	25	32	40	50	65	80	100	125	150	200	
PM280B	20~100	0.14	—	1.75	1.46										
			√	3.00	3.00										
	40~200	0.25	√	3.00	3.00										
			√	3.00	3.00										
PM400B	20~100	0.14	—			1.66	1.36	1.11							
			√			3.00	3.00	3.14							
	40~200	0.25	√			3.00	3.00	3.00							
			√			3.00	3.00	3.00							
PM600B	20~100	0.14	—						1.38	1.13	0.92				
			√						3.00	3.00	2.58				
	40~200	0.25	√						3.00	3.00	3.00				
			√							3.00	3.00	3.00			
PM1000B	20~100	0.14	—									1.19	0.99	0.75	
			√									3.00	2.80	2.12	
	40~200	0.25	√									3.00	3.00	2.80	
			√									3.00	3.00	3.00	

Table. 8 Air-to-Open Soft Sealing Type

Unit: MPa

Actuator Model	Spring Range Kpa	Air Supply MPa	Positioner	Nominal Diameter/ mm											
				20	25	32	40	50	65	80	100	125	150	200	
PM280K	20~100	0.14	√, -	1.75	1.46										
	40~200	0.25	√	3.00	3.00										
	80~240	0.28	√	3.00	3.00										
PM400K	20~100	0.14	√, -			1.66	1.36	1.11							
	40~200	0.25	√			3.00	3.00	3.00							
	80~240	0.28	√			3.00	3.00	3.00							
PM600K	20~100	0.14	√, -						1.38	1.13	0.92				
	40~200	0.25	√						3.00	3.00	2.58				
	80~240	0.28	√						3.00	3.00	3.00				
PM1000K	20~100	0.14	√, -									1.19	0.99	0.75	
	40~200	0.25	√									2.58	2.80	2.12	
	80~240	0.28	√									3.00	3.00	3.00	

1.2

Table. 9 Electric Actuated Hard Sealing Type

Unit: MPa

DN(mm) Force/ N	20	25	32	40	50	65	80	100	125	150	200
800	4.05	3.30	2.62	2.12	1.71						
1000	5.06	4.13	3.28	2.56	2.14						
2000	10.0	8.25	6.55	5.31	4.28	3.33	2.72	2.18			
3000	10.0	10.0	9.83	7.96	6.43	4.99	4.08	3.82			
4000	10.0	10.0	10.0	10.0	8.57	6.65	5.43	4.37			
5000	10.0	10.0	10.0	10.0	10.0	8.31	6.79	5.46	4.39	3.66	2.76
6500			10.0	10.0	10.0	10.0	8.83	7.10	5.70	4.76	3.58
8000			10.0	10.0	10.0	10.0	10.0	9.36	7.52	5.87	4.73
10000			10.0	10.0	10.0	10.0	10.0	10.0	8.77	7.33	5.52

M Series Cage Guided Control Valve



Table. 10.1 Pneumatic Actuated Large Diameter Valve

Unit: MPa

Actuator Model	Spring Range Kpa	Air Supply MPa	Positioner	Nominal Diameter/ mm					
				250	300	350	400	500	600
PM1600	0.25	6200	✓	2.36	1.87				
	0.40	12500	✓	4.76	3.76				
PS400	0.5	18500	✓			3.94	3.46		
PS500	0.5	23500	✓			5.27	6.66	3.92	2.72
PS600	0.5	42000	✓					5.12	3.91

Table. 10.2 Electric Actuated Large Diameter Valve

Unit: MPa

Actuator Model	Force/ N	Nominal Diameter/ mm					
		250	300	350	400	500	600
IQL18	15000	5.70	4.51				
IQL20	20000	7.60	6.02	5.34	4.82		
IQL25	32000			7.54	6.71	5.32	4.21
IQL35	55000			10.00	10.00	6.74	5.63

Notes for Permissible Differential Pressure Table:

Packing material is PTFE.

The flow direction of the medium is opposite to the closing direction of the valve core.

Values are limited by nominal pressure and the pressure-temperature chart: For bellows sealed type, when $P_2 \neq 0$, revalidation is required.

Metal sealing type leakage level is Class IV.

Special Requirements

Special Inspections,
Complete degreasing and dehydration treatment,
Copper-free treatment,
Special interfaces and piping,

Use under vacuum conditions,
Special media (e.g., oxygen),
Use of stainless steel fittings,
Specified coating color.

Connection and Standard

Connection Method: Flange Type

Flange Standard: PN16, 25, 40, 64, 100, 160 steel flanges according to GB/T9113 or other flange standard

Sealing Surface Type: PN16, 25: Raised Face (RF), PN40, 64, 100, 160: Male-Female Face, valve body is female

Face to face dimension: GB/T 12221 or ASME B16.10

*Connection method, valve body flange, and flange end face distance can be manufactured according to user-specified standards, such as HG, ANSI, DIN, JIS, etc.

Dimension and Weight/ Standard, High-Temperature, Bellow Sealing, Jacketed

1.2

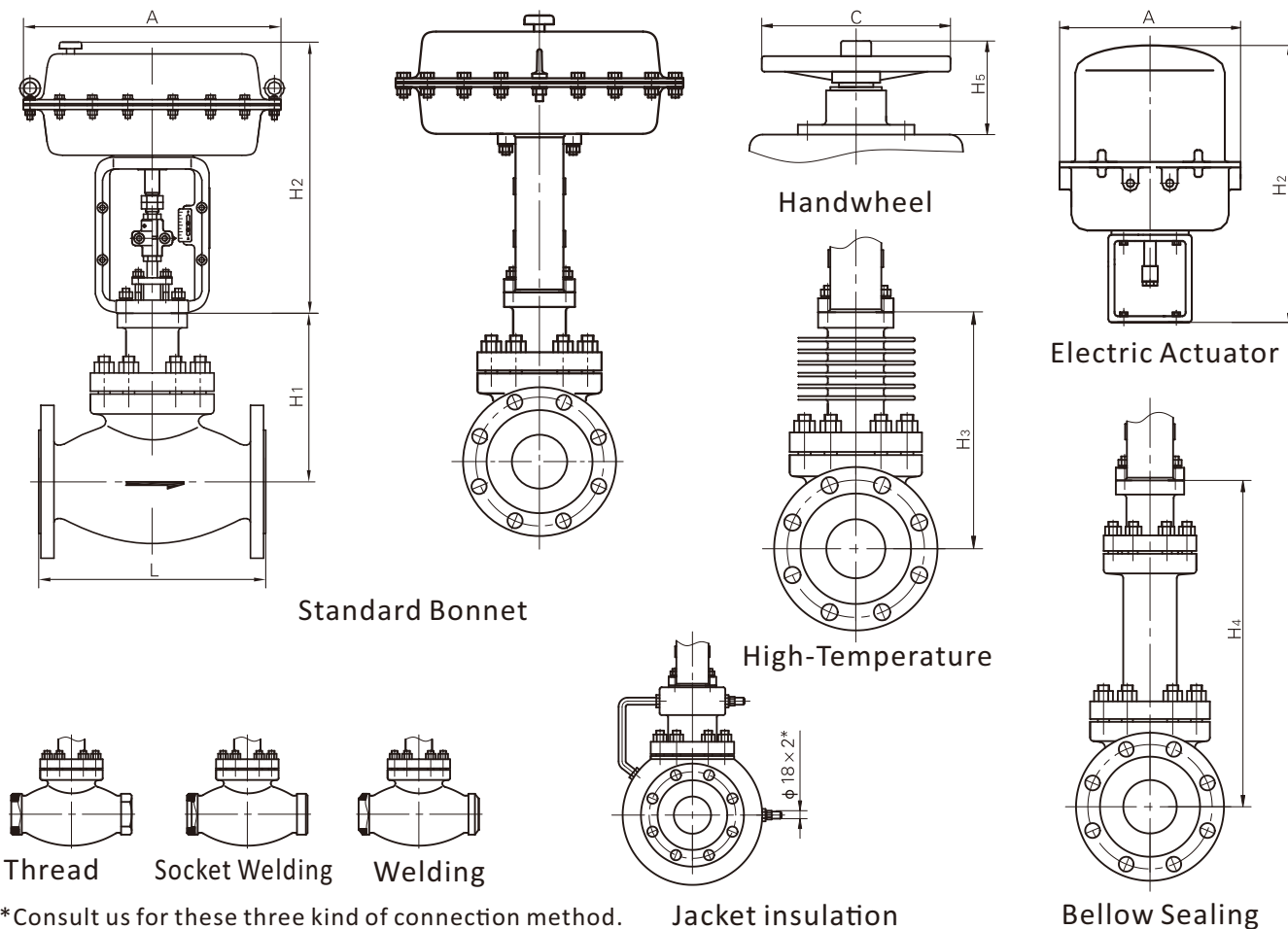

* Consult us for these three kind of connection method.

Table. 11

Unit: mm

Nominal Diameter/mm		20	25	32	40	50	65	80	100	125	150	200
L	PN16、40	150	160	180	200	230	290	310	350	400	480	600
	PN64、100	206	210	230	251	286	311	337	394	450	508	650
H ₁		146	146	179	182	186	250	252	255	305	318	372
A×H ₂	Pneumatic	Φ282×310			Φ308×396			Φ394×408			Φ504×495	
	Electric	Φ225×370			Φ255×500			Φ310×700			Φ310×750	
H ₃		196	196	212	213	218	300	302	305	380	386	448
H ₄		282	282	343	345	387	512	515	521	611	618	672
C×H ₅		Φ220×207					Φ270×242			Φ320×313		
Jacket Flange Specifications DN2		40	50	50	80	80	100	125	150	200	200	250
Weight Kg	PN16	20	21	27	32	43	69	75	77	130	152	275
	PN64	23	25	40	48	61	82	91	102	178	188	332

Note: The weights in the table are for the standard pneumatic type without manual handwheel and other accessories. The electric actuator uses the 3610 series as an example.

M Series Cage Guided Control Valve

Dimension and Weight/ Low-Temperature

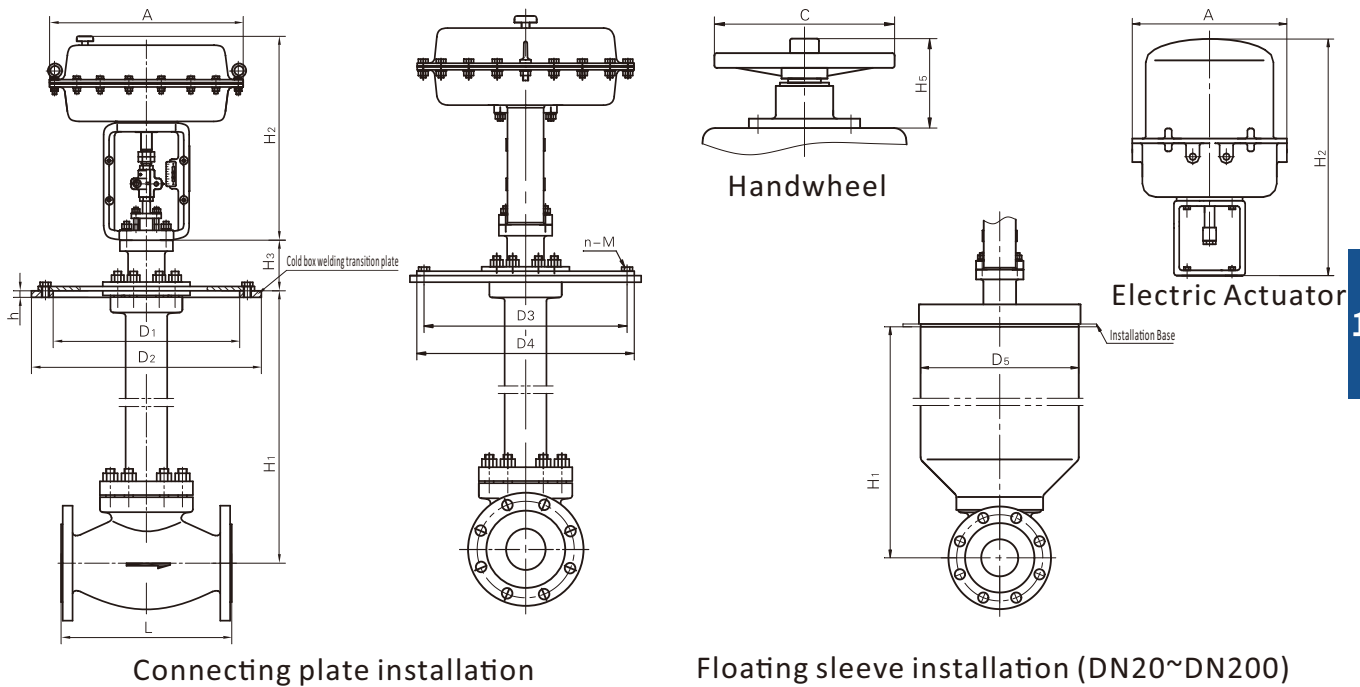

1.2

Table. 12

Unit: mm

Nominal Diameter/mm	20	25	32	40	50	65	80	100	125	150	200	
L、A x H ₂	See Table. 11											
H ₁	700											
H ₃	92							96		115		
ΦD ₁	PN16、40	230	230	250	270	305	342	375	430	490	556	665
	PN64、100	270	270	305	342	375	430	490	556	665	665	765
ΦD ₂	PN16、40	310	310	335	355	390	430	465	520	585	660	770
	PN64、100	355	355	390	430	465	520	585	600	770	770	890
h	12							15		18		
ΦD ₃	PN16、40	260	260	285	305	340	370	405	460	525	590	700
	PN64、100	305	305	340	370	405	460	525	590	700	700	805
ΦD ₄	PN16、40	290	290	315	335	370	400	435	490	555	630	740
	PN64、100	335	335	370	400	435	490	555	630	740	740	845
D ₅	Φ285							Φ470				
n-M	8-M12			8-M14		10-M14	10-M14	12-M16	14-M16	16-M16	18-M16	
C x H ₅	Φ220 x 207					Φ270 x 242			Φ320 x 313			
Weight/ Kg	25	26	36	42	50	72	75	77	174	184	346	

Note: The insulation length is taken as 700mm as an example. The weights in the table are for the PN16 standard pneumatic type without manual handwheel and other accessories.

Dimension and Weight of Large Diameter Valve/ Low-Temperature

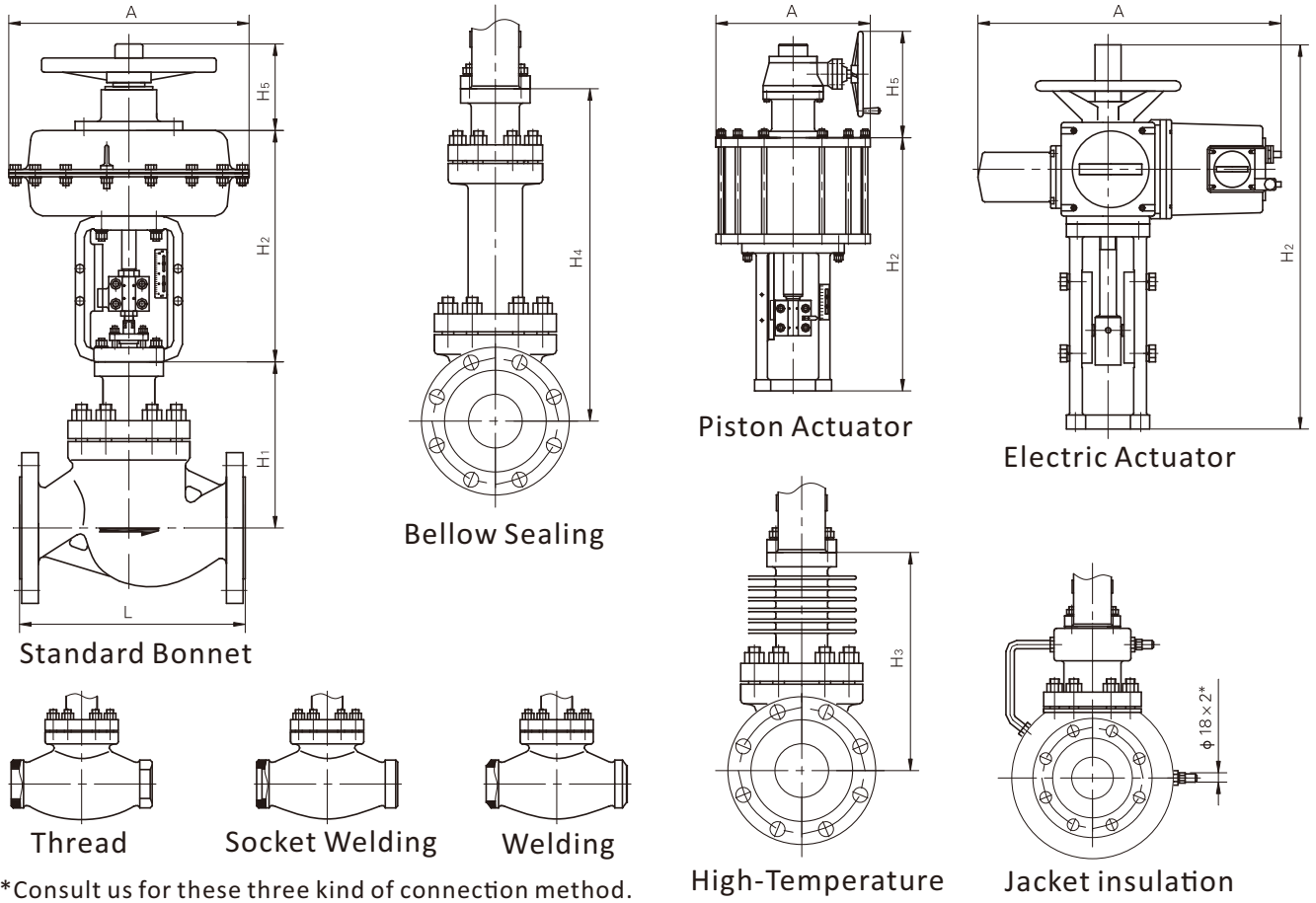

*Consult us for these three kind of connection method.

Table. 13

Unit: mm

Nominal Diameter/ mm		250	300	350	400	500	600
L	PN16	730	850	1000	1100	1375	1590
	PN25、40	750	880	1050	1135	1400	1645
	PN64	775	900	1080	1200	1435	1705
	PN100	775	930	1100	1250	1435	1705
H ₁		457	520	615	758	882	997
A×H ₂	Pneumatic	Φ615×560	Φ615×560	Φ485×915	Φ590×955	Φ692×1097	Φ692×1257
	Electric	580×725	580×725	705×840	705×840	790×1070	790×1070
H ₃		695	755	785	850	1172	1297
H ₄		795	850	980	1100	1355	1520
H ₅		480	480	595	660	750	750
Weight Kg	PN16	485	785	1350	1820	2550	3685
	PN64	592	851	1680	2350	3275	4760

Note: The weights in the table are for the standard pneumatic type without manual handwheel and other accessories. The electric actuator uses the IQ series as an example.